

Equivalent Lumped Element Network Synthesis for Distributed Passive Microwave Circuits

Johannes Russer^{#1}, Nebojša Dončov^{*2}, Farooq Mukhtar^{#3}, Biljana Stošić^{*4},
Tatjana Asenov^{*5}, Bratislav Milovanović^{*6}, and Peter Russer^{#7}

Abstract— In this paper, two compact lumped element models synthesis methods for distributed passive electromagnetic structures are presented. The first method is based on the canonical Foster representation while the second method uses the Brune's synthesis procedure which is a more general approach capable to account for lossy structures. Both methods, used in combination with a system identification approach, generate equivalent network models that can be analyzed using circuit simulators. In addition, two decomposition techniques, allow to reduce complexity in the network model synthesis by exploiting the structure's symmetry are presented. The accuracy and efficiency of the proposed methods are demonstrated on two examples: a lossless branch-line directional coupler and a lossy low-pass microstrip filter.

Index Terms— distributed passive circuit, Foster expansion, Brune's synthesis, complexity reduction techniques, network model.

I. INTRODUCTION

Full-wave electromagnetic (EM) tools are often the first choice for the design and modelling of distributed passive circuits operating at microwave and millimeter wave frequencies and at gigabit rates. However, due to processing and memory limitations, an efficient application of these tools may not be possible for computationally large problems. A division of the problem into different hierarchical modelling levels and the application of network models is a viable option for complexity reduction. Network models, in the form of compact lumped element circuits, can significantly help to correctly formulate EM problems and find their efficient solution by using methods of network theory. Network methods can be introduced on the field level by a segmentation of the EM structures under investigations [1], [2]. In general, the representation of distributed circuits by equivalent lumped element network models requires that the transfer function is first obtained either by a full-wave analysis or by measurement. Next step is to represent this transfer function in the form of a rational function by using system identification (SI) methods. Based on the location of zeros and poles of the rational function, the synthesis of an equivalent lumped element circuit can be done. This compact network model has a finite number of circuit

lumped element as it has to represent the distributed structure's transfer function in a given frequency band with a desired accuracy only.

For lossless structures, a network model can be synthesized using the Foster or Cauey canonical expansions [1], [3]. It is also possible to extend the Foster expansion to account for lossy structures [4], this however could result in circuit elements with negative real part and hence cause instability [5]. Therefore for lossy structures Brune's synthesis method is more suitable as it provides a network model with minimal number of lumped elements that are ultimately positive [3], [6]–[8]. Whereas application of either method is straightforward to implement a one-port, this is not the case for multi-ports. In addition, Brune's multi-port synthesis, though possible in principal, has not been yet demonstrated in literature [6].

Therefore, if the multi-port under investigation is symmetric, this should be exploited to reduce the number of parameters determining the network and to facilitate the implementation of the previously mentioned synthesis methods for symmetric multi-ports. In this paper, one complexity reduction technique, applicable to four-ports with two symmetry planes (double-symmetric four-ports) and one intended for two-ports with one symmetry plane (single-symmetric two-ports), are discussed and combined with the Foster and the Brune's synthesis method, respectively. The first technique, based on even and odd excitation [9], [10], allows for decomposition of double-symmetric four-port into equivalent circuits with four independent one-ports. It is used here in combination with Foster one-port synthesis and a SI method such as vector fitting [11], [13], [14] to generate the compact lumped element model for a lossless branch-line directional coupler. The second technique uses Bartlett's bisection theorem [3] to decompose a single-symmetric two-port into equivalent circuits of four one-ports of which two are independent. It is applied in combination with Brune's synthesis procedure and vector fitting method to the example of a lossy low-pass microstrip filter. In both examples, numerical full-wave analysis tools are used to initially generate the transfer function of the structures considered here.

II. SYNTHESIS METHODS FOR GENERATION OF LUMPED ELEMENT MODELS

In this section, two systematic synthesis methods for the generation of compact lumped element equivalent circuit models for passive electromagnetic structures are described.

[#]Institute for Nanoelectronics, Technische Universität München, Munich, Germany, E-mails: ¹russer@tum.de, ³mukhtar@tum.de, ⁷russer@tum.de

^{*}University of Niš, Faculty of Electronic Engineering, Aleksandra Medvedeva 14, 18000 Niš, Serbia, E-mails: ²nebojsa.doncov@elfak.ni.ac.rs, ⁴biljana.stosic@elfak.ni.ac.rs, ⁵tatjana.asenov@elfak.ni.ac.rs, ⁶bratislav.milovanovic@elfak.ni.ac.rs

A. Foster Equivalent Circuit Synthesis

In order to perform lumped element synthesis, system identifications is applied to the Z or Y parameters of one-ports. System identification is performed by means of vector fitting which identifies the poles s_k , residues B_k and terms D and E (optional) of the rational function describing the transfer function [11]. This closed form expression given in

$$Y_{ij}(s) = Es + D + \sum_{k=1}^K \frac{B_k}{s - s_k} \quad (1)$$

is obtained for each Y or Z parameters, respectively, of one-ports. The poles s_k and residues B_k are either real quantities or come in complex conjugate pairs, while terms D and E are real. For this fractional expansion, we obtain the Foster representation by identifying the appropriate inductance L and capacitance C values which allow to describe Eq. (1) by a series connection of parallel resonant circuits [1], [12].

B. Brune's Equivalent Circuit Synthesis

Equivalent lumped element circuits for general lossy two-ports, such as considered in this paper, can be obtained from Brune's circuit synthesis procedure [6], [7], [15], [16]. Cauer or Foster representations of lossless circuits, explained in subsection II-A, can be extended to lossy circuits but negative elements even for passive circuits would result. Brune's synthesis yields the realization of passive circuits with minimum number of elements. A positive real (PR) character is required for the impedance function to be synthesized. The impedance (or admittance) function is of the form:

$$W = \frac{a_n s^n + a_{n-1} s^{n-1} + a_{n-2} s^{n-2} + \dots + a_0}{b_n s^n + b_{n-1} s^{n-1} + b_{n-2} s^{n-2} + \dots + b_0} = \frac{P(s)}{Q(s)} \quad (2)$$

For W to be a PR function, the coefficients a_n, a_{n-1}, \dots, a_0 and b_n, b_{n-1}, \dots, b_0 should be positive real numbers and except for a_n, b_n, a_0, b_0 no other coefficient can be zero [3]. For a PR function, all poles and zeros are located in the left half of the complex frequency plane, or on the imaginary axis, respectively. Poles or zeros lying on the imaginary axis can be separated from the rational function without disturbing the function's PR character. In Brune's equivalent network synthesis procedure, the impedance function is analyzed and poles and zeros on the imaginary axis can be separated from the impedance (or admittance) function (2), and can be realized in a subcircuit in a straightforward manner. However, if all poles and zeros are strictly in the left half plane a special so called Brune's process is applied. The global minimum of the real part of the function on the imaginary axis is determined. The value of this global minimum is subtracted from the function. Depending on which frequency this minimum value is found at, we have to extract the real part of the impedance function (for $s = 0$ and $s = \infty$) or, if the minimum occurs at a finite frequency, we have to extract real and imaginary part.

Possible subcircuit extractions for this Brune's process are shown in Fig. 1, where W is the rational function before extraction, and W' is the reduced rational function.

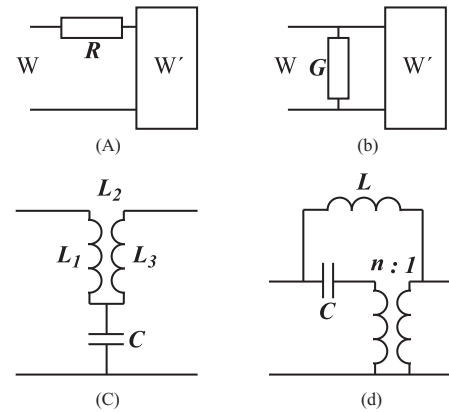

Fig. 1: Extracted circuits from Brune's process.

III. THE COMPLEXITY REDUCTION TECHNIQUES

A. Decomposition Technique for the Double-symmetric Device

Consider a four-port reciprocal EM structure which has two planes of symmetry, i.e. a horizontal (h) and vertical (v) plane of symmetry as depicted in Fig. 2(a). This symmetrical and reciprocal structure has only four independent S -parameters ($S_{11}, S_{21}, S_{31}, S_{41}$).

In order to achieve a compact lumped element circuit model without the need for a multi-port synthesis, a decomposition of the symmetrical four-port is performed.

The decomposition of the double-symmetric four-port can be performed in the following three-step procedure. In a first step, the structure under consideration is analyzed with respect to the ports' reflection coefficients by applying a full-wave electromagnetic analysis method such as the transmission line matrix (TLM) method [17]. Then, the normalized input impedance of the substructure formed by one quarter of the complete structure, as shown in Fig. 2(a), is determined for different combination of boundary conditions in the symmetry planes. For this purpose, two approaches can be used:

- Using the obtained scattering matrix parameters of the complete double-symmetric structure and by considering the condition for even (e) and odd (o) excitation, which correspond to the case of a magnetic

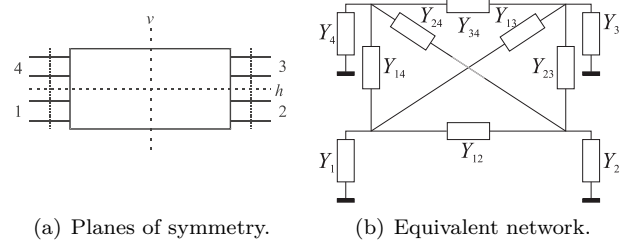

Fig. 2: Double-symmetric four-port.

wall (open circuit - *oc*) boundary condition and an electric wall (short circuit - *sc*) boundary condition, respectively, in the *h*- and *v*-plane of symmetry, the input reflection coefficient for an arbitrary port is determined as

$$\Gamma^{ee} = s_{11} + s_{21} + s_{31} + s_{41}, \quad (3)$$

$$\Gamma^{eo} = s_{11} - s_{21} - s_{31} + s_{41}, \quad (4)$$

$$\Gamma^{oe} = s_{11} + s_{21} - s_{31} - s_{41}, \quad (5)$$

$$\Gamma^{oo} = s_{11} - s_{21} + s_{31} - s_{41}, \quad (6)$$

for the various combinations of boundary conditions in the symmetry planes. The normalized input impedance of the relevant port is given as

$$z_{in}^{hv} = \frac{1 + \Gamma^{hv}}{1 - \Gamma^{hv}}, \quad (7)$$

where the indices *h* (horizontal symmetry) and *v* (vertical symmetry) are either *o* or *e*.

- $\Gamma^{hv} = s_{11}^{hv}$ can be computed directly from a single quarter of the EM structure (see Fig. 2(a)) using the full-wave EM tool while applying appropriate boundary conditions.

In the second step, a network synthesis procedure, such as the Foster synthesis, is applied to the decomposed one-ports. Four equivalent circuits will be synthesized.

In the last step, a connection network is established to realize a compact lumped element model that is integrated in a circuit simulation tool. The *S*-parameters can be obtained as follows:

$$s_{11} = (\Gamma^{ee} + \Gamma^{eo} + \Gamma^{oe} + \Gamma^{oo})/4, \quad (8)$$

$$s_{21} = (\Gamma^{ee} - \Gamma^{eo} + \Gamma^{oe} - \Gamma^{oo})/4, \quad (9)$$

$$s_{31} = (\Gamma^{ee} - \Gamma^{eo} - \Gamma^{oe} + \Gamma^{oo})/4, \quad (10)$$

$$s_{41} = (\Gamma^{ee} + \Gamma^{eo} - \Gamma^{oe} - \Gamma^{oo})/4. \quad (11)$$

The four-port can be described by a network with four distinct admittance parameters. An equivalent circuit for the four port is introduced, depicted in Fig. 2(b). From symmetry considerations we find that $Y_1 = Y_2 = Y_3 = Y_4$, $Y_{12} = Y_{34}$, $Y_{13} = Y_{24}$, and $Y_{14} = Y_{23}$ is valid for this double-symmetric four-port. The even and odd admittances Y^{hv} , where the indices *h* and *v* are either *o* or *e*, are related to the admittances Y_{ij} of the network shown in Fig. 2(b) by

$$Y_1 = 2Y^{ee}, \quad (12)$$

$$Y_{12} = 1/2(-Y^{ee} + Y^{eo} - Y^{oe} + Y^{oo}), \quad (13)$$

$$Y_{13} = 1/2(-Y^{ee} + Y^{eo} + Y^{oe} - Y^{oo}), \quad (14)$$

$$Y_{14} = 1/2(-Y^{ee} - Y^{eo} + Y^{oe} + Y^{oo}). \quad (15)$$

Negative contributions to the admittance in Eqs. (12)-(15) can be realized by transformation network, as depicted in Fig. 3, where $Y_{ij} = Y'_{ij} + Y''_{ij}$, with Y'_{ij} being a positive and Y''_{ij} being a negative contribution to the admittance.

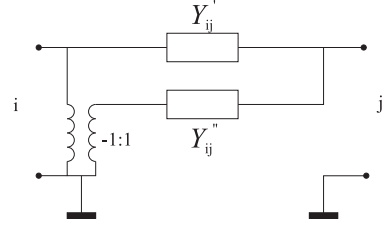
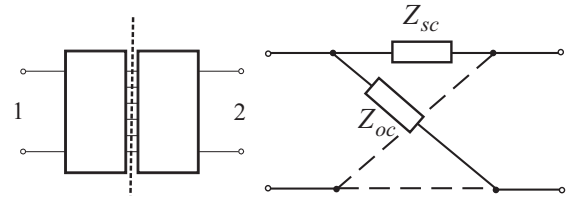

Fig. 3: Transformation network for negative elements.

B. Decomposition Technique for the Single-symmetric Device

Consider a two-port reciprocal EM structure which has one symmetry plane as depicted in Fig. 4(a). This symmetrical and reciprocal structure has only two independent *S*-parameters (S_{11} , and S_{21}). Bartlett's theorem [3] allows to transform symmetric two-port device into equivalent circuit consisting of four one-ports. The one-ports obtained from Bartlett's decomposition can be synthesized by Brune's process. Structure is equivalent to a lattice network illustrated in Fig. 4(b) with series branches of Z_{sc} and cross branches of Z_{oc} . The impedances Z_{sc} and Z_{oc} , or admittances Y_{sc} and Y_{oc} , respectively, can be computed from [3].



(a) Plane of symmetry. (b) Equivalent lattice circuit.

Fig. 4: Single-symmetric two-port.

IV. NUMERICAL ANALYSIS RESULTS

A. Modeling of a Double-Symmetric Branch Line Coupler

A branch-line coupler was chosen to demonstrate the compact equivalent network synthesis for the double-symmetric four-port. The branch-line coupler, shown in Fig. 5, has a patch thickness of 0.1 mm, a substrate height of 0.8 mm, substrate permittivity of 2.2, and is designed to operate around 6.5 GHz. The metallization is made of PEC.

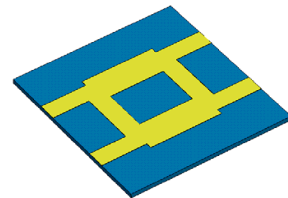

Fig. 5: Branch-line coupler.

The *S*-parameters are obtained from a full-wave electromagnetic analysis, accounting for the entire structure as discussed in Section III-A. The magnitude and phase of

S_{11} , S_{21} , S_{31} and S_{41} are plotted in Fig. 6. Alternatively, the reflection coefficients are obtained for the structure truncated at the planes of symmetry, with the appropriate boundary conditions enforced and subsequently the S -parameters are obtained from Eqs. (8)-(11). This yields equivalent results to the simulation of the entire structure (see Fig. 6). After obtaining the four distinct reflection coefficients for the odd and even cases, the respective impedances are obtained from Eq. (7), system identification is performed and a lumped element realization is obtained using the Foster representation.

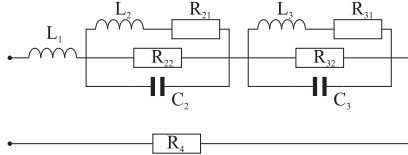

Fig. 7: Foster circuit for the decomposed one-ports.

	Z^{ee}	Z^{eo}	Z^{oe}	Z^{oo}
L_1	3.36×10^{-10}	2.75×10^{-10}	3.66×10^{-10}	5.98×10^{-10}
L_2	n/a	1.52×10^{-9}	1.24×10^{-9}	n/a
R_{21}	n/a	-9.19×10^{-2}	-4.65×10^{-2}	n/a
R_{22}	1.00×10^5	1.54×10^4	6.69×10^3	2.08
C_2	1.47×10^{-12}	6.62×10^{-13}	9.63×10^{-13}	8.92×10^{-12}
L_3	6.41×10^{-10}	3.59×10^{-10}	5.04×10^{-10}	1.27×10^{-9}
R_{31}	-5.7×10^{-1}	-2.16×10^{-1}	-9.05×10^{-1}	-6.18×10^{-1}
R_{32}	2.17×10^3	2.45×10^3	9.52×10^2	2.41×10^3
C_3	4.16×10^{-13}	4.98×10^{-13}	5.05×10^{-13}	4.43×10^{-13}
R_4	9.60×10^{-1}	3.56×10^{-1}	1.86	1.00×10^{-6}

TABLE I: Values for the lumped elements of the Foster circuits for Z^{ee} , Z^{eo} , Z^{oe} and Z^{oo} (L in Henrys, R in Ohms, and C in Farads).

The obtained lumped element circuits are shown in Fig. 7 and Table I. Results for the S -parameters obtained from synthesized equivalent Foster circuits for the one-ports of Z^{ee} , Z^{eo} , Z^{oe} and Z^{oo} , applying Eqs. (8)-(11), are given in Fig. 8. Each decomposed one-port has been synthesized using 5 poles. A very good agreement between the original results of the full-wave analysis and equivalent lumped element model has been achieved. A lumped element network model of the complete double symmetric branch-line coupler can be obtained from Eqs. (12)-(15).

B. Microstrip Low-pass Filter

For the numerical study, we consider a low-pass microstrip filter, shown in Fig. 9, to demonstrate the two methods for synthesis of compact lumped element models for linear lossy reciprocal two-port devices described above. The physical dimensions of symmetrical low-pass

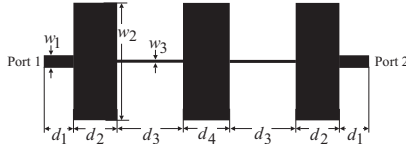
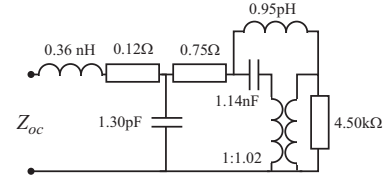

Fig. 9: Layout of microstrip low-pass filter.

filter in millimeters are: line widths $w_1 = 0.217054$, $w_2 = 2.31921$ and $w_3 = 0.0248336$; line lengths $d_1 = 0.566318$,

$d_2 = 0.84057$, $d_3 = 1.29201$ and $d_4 = 0.901333$. The substrate height is $h = 0.2$ mm, its relative permittivity is $\epsilon_r = 12.9$ and $\tan\delta = 0.004$. The metallization is made of copper. The full wave EM analysis results are obtained from TLM simulations. In order to generate the equivalent circuit, impedance parameters of the full-wave analysis have to be de-embedded. Compact lumped element model obtained by Brune's synthesis procedure is shown in Fig. 10. Before applying Brune's method, symmetric two-port device from Fig. 9 is first transformed into a connection of one-ports using Bartlett's theorem. These one-ports are then synthesized by Brune's process which yields a minimum number of elements.



(a) Equivalent Brune's circuit of Y_2

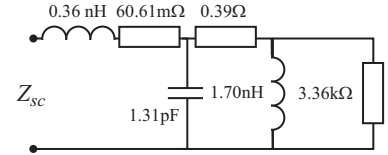

(b) Equivalent Brune's circuit of Y_1

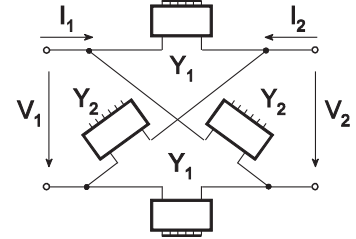

(c) Equivalent Bartlett's circuit

Fig. 10: Equivalent Brune's circuit.

Fig. 11 compares the synthesized equivalent Foster and Brune's circuit scattering matrix results to the results obtained directly from EM simulation.

V. CONCLUSION

In this paper we have presented a compact lumped element circuit synthesis for single and double-symmetric devices. Two complexity decomposition techniques enable a generation of circuit models without the need for a multi-port network synthesis procedure. The decomposition has been demonstrated in the analysis of a double-symmetric branch-line coupler and a single-symmetric low-pass filter. The decomposed one-ports have been synthesized using the Foster and Brune representations and results for the S -parameters were presented.

ACKNOWLEDGEMENT

The authors thank the Deutschem Akademischem Austauschdienst (DAAD) and the Serbian Ministry for Education and Science for their support of this work. Also, this

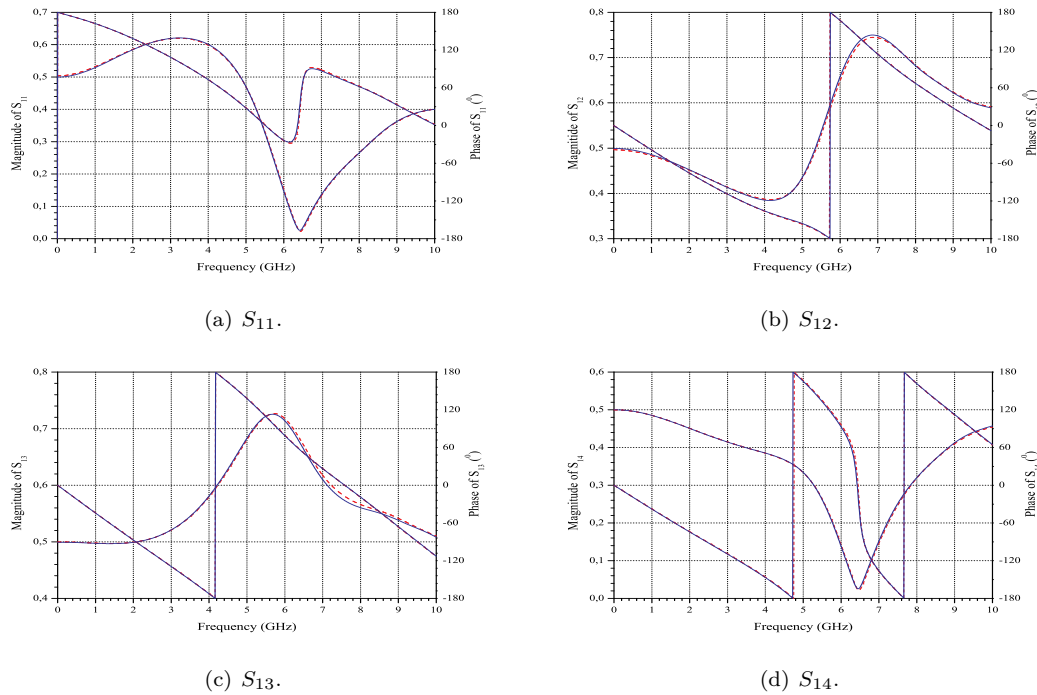

Fig. 6: Magnitude of scattering matrix parameter obtained by full-wave EM analysis of complete branch-line coupler (red dashed line) and full-wave EM analysis of one quarter of the Branch-line coupler (blue solid line).

work has been partially supported by the Serbian Ministry for Education and Science under the project TR-32052.

A part of the results shown in this paper is presented on 10th International Conference on Telecommunications in Modern Satellite, Cable and Broadcasting Services - TELSIS 2011, Serbia, Niš, October 5-8, 2011.

REFERENCES

- [1] L.B. Felsen, M. Mongiardo, and P. Russer, *Electromagnetic Field Computational by Network Methods*, Berlin, Germany: Springer, March 2009.
- [2] J.A. Russer, Y. Kuznetsov, and P. Russer, "Discrete-time Network and State Equation Methods Applied to Computational Electromagnetics", *Microwave Review*, Vol. 16, No. 1, pp. 2-14, 2010.
- [3] Ernst A. Guillemin, *Synthesis of Passive Networks*, New York: Wiley, 1957.
- [4] I. Timmins, Ke-Li Wu, "An Efficient Systematic Approach to Model Extraction for Passive Microwave Circuits", *IEEE Transactions on Microwave Theory and Techniques*, Vol. 48, No. 9, 2000.
- [5] N. Doncov, F. Mukhtar, J. Russer, B. Stosic, B. Milovanovic, P. Russer, "Methods for Generation of Compact Lumped Element Model for Passive Microwave Circuits", *XLVI Int. Scientific Conf. in Information, Communication and Energy Systems and Technologies - ICEST 2011*, Nis, Serbia, 29 June - 1 July 2011, Vol. 1, pp. 163-166.
- [6] V. Belevitch, "On the Brune Process for n-Ports", *IRE Transactions on Circuit Theory*, Vol. 7, No. 3, pp. 280-296, September, 1960, DOI=10.1109/TCT.1960.1086674.
- [7] Otto Brune, "Synthesis of a Finite Two-terminal Network whose Driving-point Impedance is a Prescribed Function of Frequency" *Journal of Mathematical Physics*, Vol. 10, No. 3, pp. 191-236, 1931.
- [8] F. Mukhtar, Y. Kuznetsov, and P. Russer, "Network Modelling with Brune's Synthesis", *Advances in Radio Science*, Vol. 9, pp. 91-94, 2011.
- [9] R. E. Collin, *Foundations for Microwave Engineering*, New York, IEEE Press, 2001.
- [10] J. Russer, N. Doncov, F. Mukhtar, B. Stosic, B. Milovanovic, P. Russer, "Compact Equivalent network Synthesis for Double-Symmetric Four-Ports", *10th International Conference on Telecommunications in Modern Satellite, Cable and Broadcasting Services - TELSIS 2011*, Serbia, Niš, October 5-8, 2011, Vol. 2, pp. 383-386.
- [11] B. Gustavsen and A. Semlyen, "Rational Approximation of Frequency Domain Responses by Vector Fitting", *IEEE Transactions on Power Delivery*, Vol. 14, No. 3, pp. 1052-1061, July, 1999, DOI: 10.1109/61.772353, <http://dx.doi.org/10.1109/61.772353>
- [12] V. Belevitch, *Classical Network Theory*, CA, San Francisco, Holden-Day, 1968.
- [13] B. Gustavsen, "Improving The Pole Relocating Properties of Vector Fitting", *IEEE Transactions on Power Delivery*, Vol. 21, No. 3, pp. 1587-1592, July 2006.
- [14] D. Deschrijver, M. Mrozowski, T. Dhaene, and D. De Zutter, "Macromodeling of Multiport Systems using a Fast Implementation of the Vector Fitting Method", *IEEE Microwave and Wireless Components Letters*, Vol. 18, No. 6, pp. 383-385, June 2008.
- [15] F. Mukhtar, Y. Kuznetsov, C. Hoffmann, P. Russer, "Brune's Synthesis of Linear Lossy Distributed One-port and Symmetric Two-port Microwave Circuits", *German Microwave Conference - GeMiC 2011*, Darmstadt, Germany, March 2011, pp.1-4, 14-16.
- [16] Y. Kuznetsov, A. Baev, T. Shevgunov, U. Siart, H. Jordanov, and P. Russer, "Generation of Network Models for Planar Microwave Circuits by System Identification Methods", *Proceedings of International Conference on Electromagnetics in Advanced Applications - ICEAA'09*, pp. 966-969.
- [17] Christos Christopoulos, *The Transmission Line Matrix Method TLM*, IEEE Press, New York, 1995.

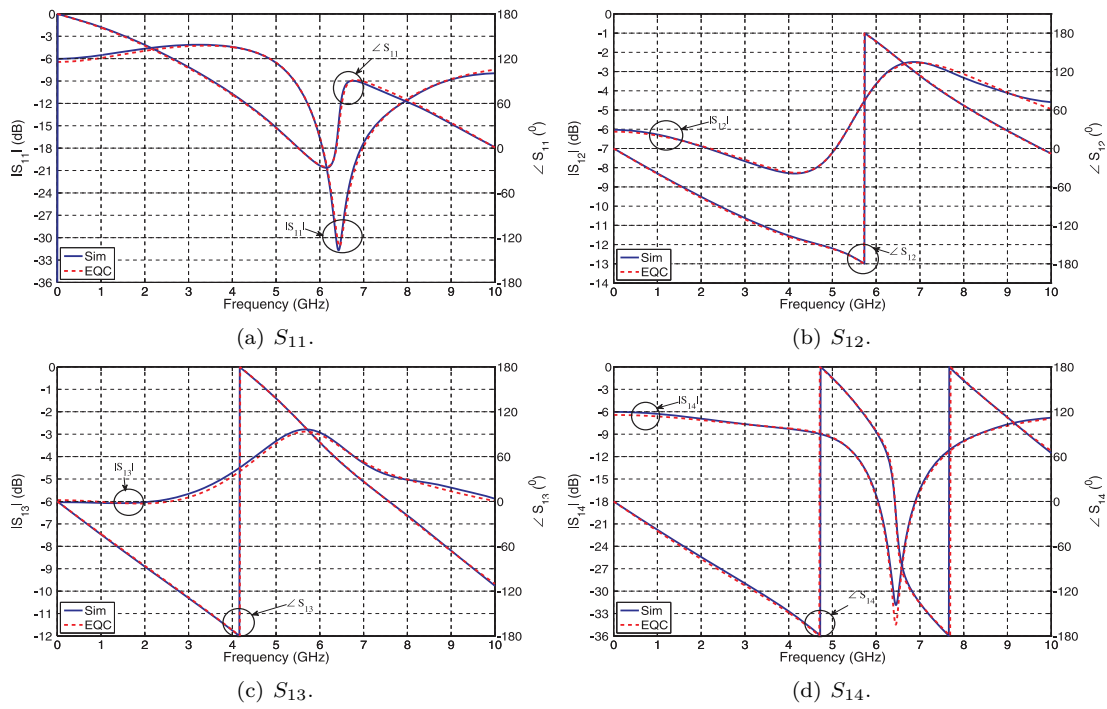

Fig. 8: Magnitude and phase of scattering matrix parameter obtained by full-wave EM analysis of the branch-line coupler directly (blue solid line) and from the synthesized equivalent circuit for the branch-line coupler (red dashed line).

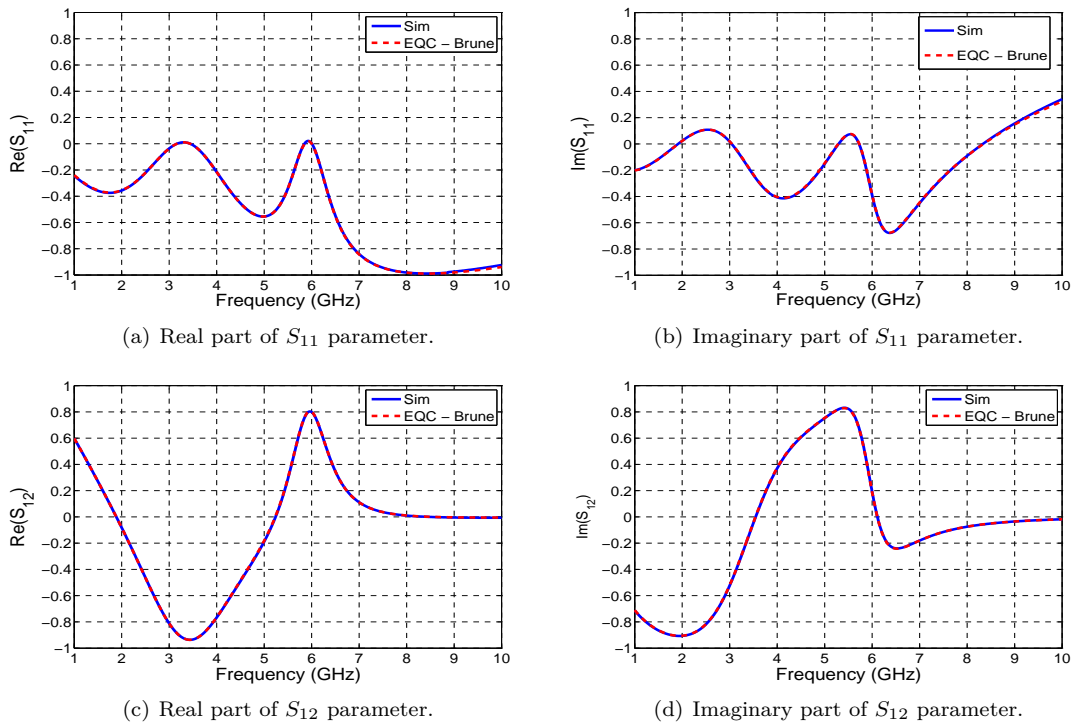

Fig. 11: S parameters of low-pass filter.