

Effect of Progressive Phase Excitation on Tunability of Rectangular Patch Array Antenna Printed on Synthesized LiTiZn Ferrite

Dheeraj Kumar¹, Naveen Kumar Saxena² and Bhoopendra Singh²

Abstract – In the present communication effects of progressive phase excitation on the radiation characteristics of microstrip antenna array imprinted on synthesized LiTiZn ferrite substrate in external magnetic field are analyzed. Usually ferrite based microstrip antennas are preferred for the scanning and tracking purpose due to its non-reciprocal behavior under biased condition. The scanning behavior of radiation beam can be controlled by varying magnetic field without any mechanical exercise, moreover this scanning effect enhanced considerably by changing the phase excitation of feeding current of antenna array. Phase excitation technique with magnetic biasing improve the effective radiation which is generally slow down due to high biasing field.

Keywords – Synthesized Ferrite, Microstrip Antenna Array, Miniaturization, Switchable Antenna, X Band

List of Symbols

f_r	=	Resonant frequency
h	=	Height of substrate
λ	=	Wavelength
β_x, β_y	=	Progressive phase excitation difference along x and y direction respectively
d_x, d_y	=	Element separation along x and y direction respectively
α	=	Attenuation constant
β	=	Phase constant
β_0	=	Propagation constant in vacuum
ϵ_r	=	Dielectric constant
μ_{eff}	=	Effective permeability
μ, κ	=	Permeability tensor components of μ_{eff}
T	=	Relaxation time
H_0	=	Applied bias field
ΔH	=	Magnetic resonance width of ferrite
ω	=	Angular frequency of incident e-m-waves
ω_0	=	External magnetic field angular frequency
ω_m	=	Internal magnetic field angular frequency

μ'	=	Real part of permeability
μ''	=	Dissipative part of permeability
χ'	=	Real part of susceptibility
χ''	=	Dissipative part of susceptibility
$4\pi M_s$	=	Saturation magnetization
γ	=	Gyromagnetic ratio (2.8 MHz / Oe.)

I. INTRODUCTION

Although Ferrite materials have been used extensively in microwave devices such as circulators, phase shifters, filters and delay lines, relatively little research effort has been devoted to the problem of antennas in the presence of ferrite materials until recently [1- 4]. The use of ferrite substrates for printed antennas and circuitry is also interesting because it allows a controllable degree of freedom that is unattainable with other substrates. It is established that when a ferrite is placed in a biased DC magnetic field H_0 , its magnetization vector starts precessing about this field by a frequency proportional to H_0 , thus rendering a material with an intrinsic eigen frequency and microwave properties strongly dependent on the frequency of the r.f. field [5]. Furthermore, since the ferrite eigen frequency depends on the bias field, the properties of the material can change to a certain degree by simply changing the biased field [6]. Previous research conducted by Saxena, Kumar, and Pourush has also examined microstrip rectangular patch antennas printed on LiTi Ferrite with perpendicular DC magnetic biasing [7]. This research has found that the introduction of such biasing significantly influences the antenna's characteristics and performance, providing an additional perspective on the use of ferrite materials in antenna designs. Das and his co-workers [8-9] have utilized ferromagnetic substrate with high effective permeability in order to reduce the size of printed antennas when operating at low UHF frequencies. Pozar and Sanchez [10] have studied experimentally the tuning of a microstrip antenna on ferrite substrate by varying its relative position with respect to small magnet. Yang and his colleagues [11-12] have studied the infinite phased array problem of dipole and patch antennas on ferrite substrate and they have shown some of the effects of the bias field strength and orientation. Batchelor and Langley [13] describe the beam scanning properties of a 2-element patch array fed by a microstrip feed situated on a ferrite substrate. G.F. Dionne, D.E. Oates, D.H. Temme, and J.A. Weiss [14-17] excellently implemented the non-reciprocal behavior of ferrite and they have done a significant work in the area of low loss phase shifters. The size miniaturization of a microstrip antenna is efficiently achieved using inductive (magnetic) loading according to Hansen and Burke [18]. A study conducted by

Article history: Received March 03, 2023; Accepted October 11, 2023

¹Dheeraj Kumar is with Department of Physics and Electronics, Rajdhani College (University of Delhi) New Delhi, India, E-mail: kdheeraj_7@yahoo.co.in

²Naveen Kumar Saxena and Bhoopendra Singh are with Microwave Lab, Department of Physics, Agra College, Agra, India, Email: Nav3091@gmail.com, bhoopen2773@yahoo.com

Ikonen et al. [19-21] investigated the effect of frequency dispersion of a magneto-dielectric substrate on impedance bandwidth properties of a loaded antenna.

The above review examines the nonreciprocal behavior of ferrite materials and its applications under d-c biased conditions with magnetostatic waves including spin wave exchange term. The reason behind the inclusion of this term is due to the fact that the incident plane waves propagate through the biased ferrite substrate in the microwave frequency range, the wavelength of em-waves approaches the interatomic distance, which results in an additional term in addition to quasi-TEM waves, known as magnetostatic waves. Magnetostatic wave analysis of ferrite is very recent and has applications in microstrip antenna radome layers. As a result of ferrites, significant contributions have been made to the study of ferromagnetic materials that have unusually high resistivity in order to obtain reasonable eddy current losses on a ferromagnetic material when it is immersed in an alternating magnetic field. In order to reduce these losses, the ferromagnetic core can be laminated to restrict eddy current paths, but there is a practical limit to how thick limitations can be made. In ferromagnetic materials, eddy current losses are inversely proportional to resistivity. Thus at microwave frequencies, unusually high resistivity is imperative since eddy current is proportional to the square of frequency. The eddy current losses in ferrites with a resistivity of 10^7 ohm meters as compared to 10^{-7} ohm meters for iron are negligible at microwave frequencies [22].

Ferrite based microstrip antennas are only option for scanning and tracking applications, when mechanical movement and compactness of antenna are limitation. Due to the non-reciprocal behavior of ferrite substrate varying biased field arise the scanning behavior of radiation beam but slightly change in phase excitation of feeding current, this scanning effect enhanced considerably. Using phase excitation with biasing increases the effective radiation which is generally retarded due to high biasing field.

In the present paper, the effects of progressive phase excitation on the radiation characteristics of a microstrip antenna array imprinted on the biased LiTiZn ferrite substrate operating at a frequency of 10 GHz were examined using Matlab for simulation.

II. ARRAY STRUCTURE

The Antenna array design is illustrated in Fig. 1. Sixteen similar microstrip patch antennas of length L and width W are imprinted on LiTiZn ferrite substrate of thickness h . The power supply is linked to the center of the array through a coaxial feed from the rear side of the substrate. This power is then evenly distributed to each of the radiating elements via Tee junction power dividers and quarter-wave transformer impedance matching sections. Fig. 2 provides a detailed side view of the coaxial probe feeding system [32]. Solid state reaction technique is used to synthesize LiTiZn ferrite from the natural lithium ferrites composition. Experimental measurements were conducted in the laboratory to determine the physical properties of LiTiZn ferrite, as shown in Table 1.

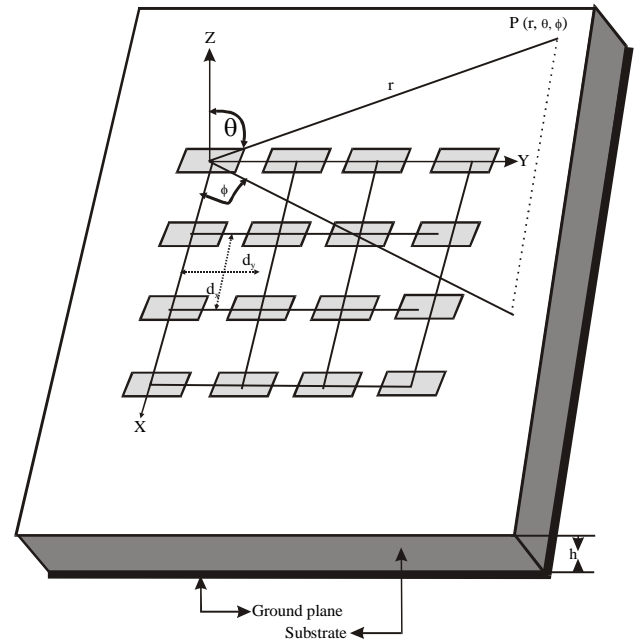

Fig. 1. Design of 4x4 rectangular patch antenna array

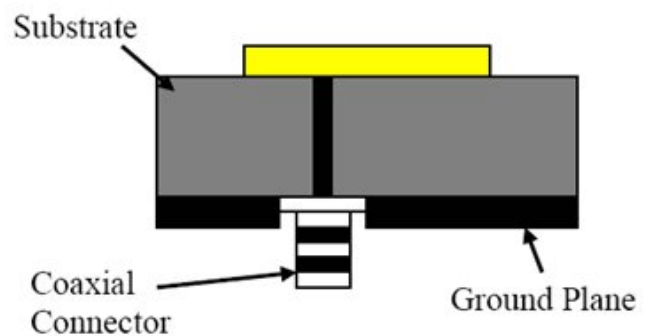

Fig. 2 Side view of the coaxial probe feeding system

TABLE 1
PHYSICAL PROPERTIES OF LiTiZn FERRITE SUBSTRATE

LiTiZn Ferrite Characteristics	Values
Magnetic Saturation ($4\pi M_s$)	2200 Gauss
Curie Temperature (T_c)	385 K
Density (ρ)	4.21 grams/cm ³
Remanence	0.90
Coercivity	1.50
Dielectric Constant (ϵ)	16
Resonance Line Width (ΔH)	370 Oe
Loss Tangent ($\tan\delta$)	< 0.0005

III. THEORY

The vector permeability tensor for a ferrite in external magnetic field is given by [23]:

$$[\mu] = \begin{bmatrix} \mu & jk & 0 \\ -jk & \mu & 0 \\ 0 & 0 & 1 \end{bmatrix} \quad (1)$$

Where

$$\mu = 1 + \frac{\omega_r \omega_m}{\omega_r^2 - \omega^2} \text{ and } k = \frac{\omega \omega_m}{\omega_r^2 - \omega^2} \quad (2)$$

$$k^2 = \omega^2 \epsilon \mu_0 \frac{(\omega_r + \omega_m)^2 - \omega^2}{\omega_r^2 + \omega_r \omega_m + \omega^2} \quad (3)$$

$$\omega^2 = \frac{\frac{k^2}{\epsilon \mu} + (\omega_r + \omega_m)^2 \pm \left[\left(\frac{k^2}{\epsilon \mu} + (\omega_r + \omega_m)^2 \right)^2 - 4(\omega_r^2 + \omega_m \omega_r) \frac{k^2}{\epsilon \mu} \right]^{\frac{1}{2}}}{2} \quad (4)$$

Ordinary and extraordinary waves are generated at normal incidence plane wave on magnetized ferrite substrate. The nature of ordinary wave is not influenced by the external magnetic field and as it would propagate in unbiased medium. On other hand, the behavior of the extra ordinary wave is regulated by the external magnetic field. Applied magnetic field stimulates oscillations in the ferrite substrate and they propagate in it with a defined velocity due to the elasticity of substrate. These oscillations constitute magnetostatic waves (MSW) and spin waves when magnetic biasing is normal to magnetic vector of incident plane waves [24-27]. The extraordinary wave is decaying when effective permeability (μ_{eff}) of ferrite is negative. μ_{eff} is negative in the frequency range:

$$\sqrt{\omega_0(\omega_0 + \omega_m)} < \omega < (\omega_0 + \omega_m) \quad (5)$$

Ferrites exhibit interesting properties within this frequency limits. External magnetic field is applied to regulate the behavior of extraordinary wave and a switchable antenna is designed on the basis of this concept. The antenna do not radiate within the above frequency range when extraordinary wave propagate through LiTiZn substrate and it radiate effectively when ordinary wave propagate through ferrite as in normal dielectric medium[28]. The total fields of the antenna array can be obtained by the field of single antenna multiplied by the array factor. Thus the far zone field of proposed antenna are obtained as follow [31-32]:

$$R(\theta, \varphi) = (|E_\theta|^2 + |E_\varphi|^2) \times AF \quad (6)$$

where

$$E_\theta = 0 \text{ and } E_\varphi = -2jV_0 WkF(\theta, \varphi) \quad (7)$$

$$F(\theta, \varphi) = \frac{\sin(\frac{kh}{2} \sin\theta \cos\varphi)}{\frac{kh}{2} \sin\theta \cos\varphi} \times \frac{\sin(\frac{kh}{2} \cos\theta)}{\frac{kh}{2} \cos\theta} \sin\theta \quad (8)$$

Using the pattern multiplication approach and neglecting mutual coupling between the elements, the normalized form of the array factor for the present geometry is obtained and given as:

$$AF = 0.0625 \frac{\sin\{2(Kd_x \sin\theta \cos\varphi + \beta_x)\}}{\sin\{0.5(Kd_x \sin\theta \cos\varphi + \beta_x)\}} \times \frac{\sin\{2(Kd_y \sin\theta \sin\varphi + \beta_y)\}}{\sin\{0.5(Kd_y \sin\theta \sin\varphi + \beta_y)\}} \quad (9)$$

Equation (9) indicates that the pattern of a rectangular array is the product of the array factors of the arrays in the x- and y-directions.

IV. RESULTS AND DISCUSSION

Dispersion curve is plotted in Fig. 3 for normal biased field. It clearly shows that the value of propagation constant become zero two-time at the cutoff frequency, this is the consequence of the excitation of quasi-TEM, magnetostatic waves (MSW) and spin waves [26-30]. The propagation constant initially varies linearly, form a curve and reached to saturation level with frequency. The linear, curve and saturation part of the plot represents quasi TEM wave, MSW and Spin wave excitation respectively. Quasi TEM wave excitation is extremely small (10-100) in comparison of scale (10^8). Exchange forces between atoms generates the spin waves. According to Fig. 3 the absorbing power due to the MSW generation is in a particular range and this range determined by the thickness of substrate, resonance line width of ferrite and orientation of external magnetic field. The radiation patterns of the antenna array are obtained considering resonant frequency = 10 GHz, $\epsilon_r = 16$, $h = 1.65$ mm, $W = 7.884$ mm, $L_{\text{eff}} = 5.609$ mm, loss tangent = 0.0005 and separation among elements $d_x = d_y = \lambda/2$. Radiation patterns corresponding to different progressive phase excitations ($\beta = \lambda, \lambda/2, \lambda/3, \lambda/4$) have been represented in Fig. 4-7. These visuals highlight the critical role of phase excitation value selection, particularly under the influence of an external magnetic field. The ensuing impacts are of dual nature: steering of the main lobe and attenuation of minor side lobes.

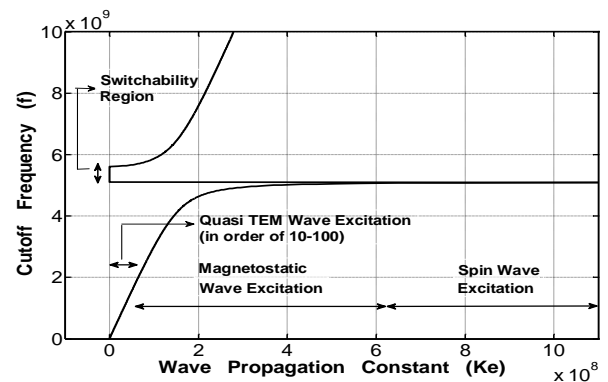

Fig. 3. Dispersion curve for LiTiZn Ferrite substrate in external magnetic field

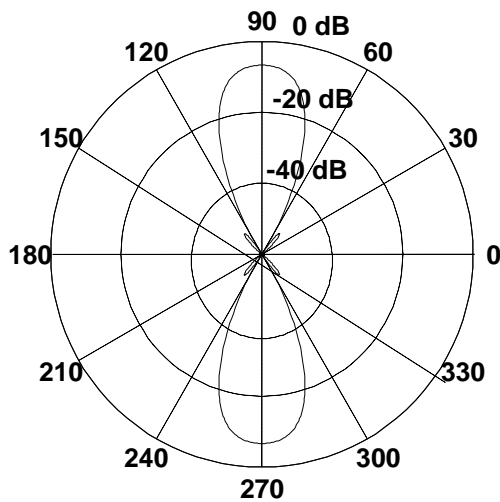

Fig. 4. Radiation patterns of antenna array for phase excitation $\beta = \lambda$ in external magnetic field ($H_0 = 1000 \text{ Oe}$)

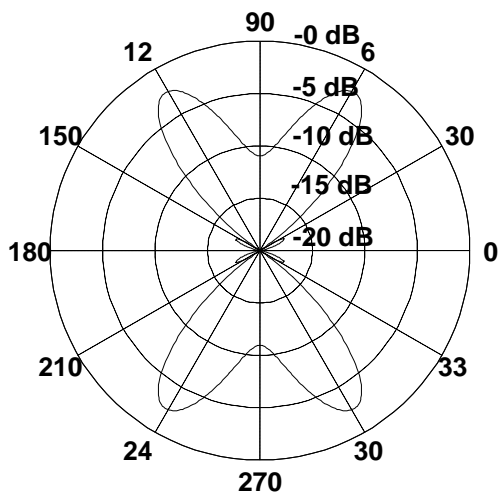

Fig. 5. Radiation patterns of antenna array for phase excitation $\beta = \lambda/2$ in external magnetic field ($H_0 = 1000 \text{ Oe}$)

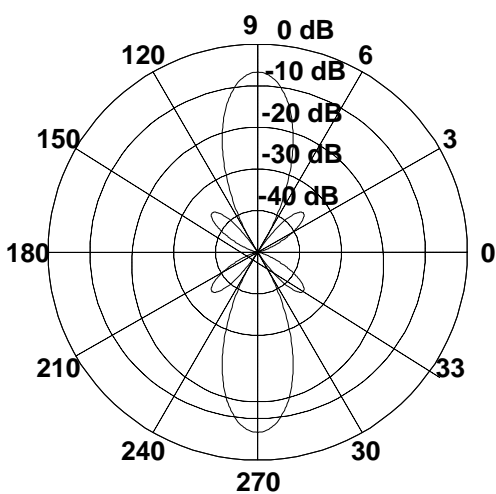

Fig. 6. Radiation patterns of antenna array for phase excitation $\beta = \lambda/3$ in external magnetic field ($H_0 = 1000 \text{ Oe}$)

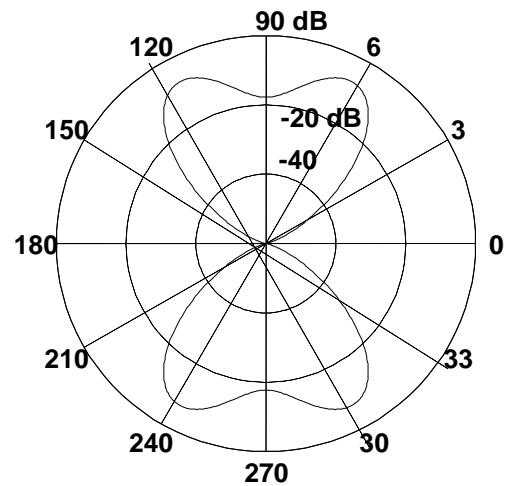

Fig. 7. Radiation patterns of antenna array for phase excitation $\beta = \lambda/4$ in external magnetic field ($H_0 = 1000 \text{ Oe}$)

As evidenced in Fig. 7, when the phase excitation is $\beta = \lambda/4$ under an external magnetic field ($H_0 = 1000 \text{ Oe}$), minor lobes disappear. On the other hand, for phase excitations $\beta = \lambda, \lambda/2$, and $\lambda/3$ within the same magnetic field ($H_0 = 1000 \text{ Oe}$), the patterns showcase beam steering of main lobes along with a redistribution of minor side lobes, as displayed in Fig. 4-6. Furthermore, analysis of far-field radiation patterns reveals that utilizing ferrite as a substrate in an external magnetic field can reduce the effect of mutual coupling along with reduction of radiation power and redistribution of minor side lobes in isotropic manner.

V. CONCLUSION

Analysis of the dispersion curve reveals that the antenna does not radiate in the frequency range of 5 GHz - 5.5 GHz for the given parameters. Hence, the antenna can be considered 'off' as a transmitter in this specific range. This insight is derived directly from the dispersion curve, where the propagation constant, indicative of wave propagation characteristics, becomes zero. These findings are pivotal for the development of a switchable antenna, where the functioning state (on/off) can be modulated by varying the external magnetic field. This ability to manipulate the antenna's operation through external conditions presents a new direction in antenna design. Furthermore, a comparative study demonstrates that using a ferrite substrate leads to a 62% reduction in the antenna's size compared to an antenna designed on a Quartz substrate. This conclusion is reached by evaluating the physical dimensions of the antennas under the different substrate conditions. Such significant miniaturization holds immense potential for applications that demand compact antennas, especially in space and cellular communications. It directly responds to the pressing need for smaller, more efficient communication devices. Finally, analysis of radiation patterns shows that by altering the phase excitation, the radiation pattern can become more directional. This directional characteristic provides a significant advantage in beam scanning, a crucial attribute for efficient signal transmission and reception. The study of ferrite-based microstrip antennas reveals several enhancements, including

size reduction, switchability, and improved beam scanning. These collective improvements have the potential to revolutionize antenna design and application.

REFERENCES

- [1] D. M. Pozar, "Radar-Cross Section of Microstrip Antenna on Normally Biased Ferrite Substrate", *Electronic Letters*, vol. 25, no. 16, pp. 1079-1080, 1989.
- [2] D. Kumar, P.K.S. Pourush, "Circular Patch Microstrip Array Antenna on Nicoal Ferrite Substrate in C-Band", *Journal of Magnetism and Magnetic Materials*, vol. 322, pp. 1635-1638, 2010.
- [3] E. Buris Nicholas, B. Funk Timothy, and S. Silverstein Robert, "Dipole Arrays Printed on Ferrite Substrates", *IEEE Transactions Antenna and Propagation*, vol. 41, no. 2, pp. 165-175, 1993.
- [4] Yang-Yu Hang, A. Jesse Castenda, and G. Nicolaos Alxopoulou, "The RCS of a Microstrip Patch on an Arbitrarily Biased Ferrite Substrate", *IEEE Transactions Antenna and Propagation*, vol. 41, no. 12, pp. 610-184, 1993.
- [5] L. Landau, E. Lifshitz, "On the Theory of the Dispersion of Magnetic Permeability in Ferromagnetic Bodies", *Perspectives in Theoretical Physics*, vol. 8, pp. 153-164, 1935.
- [6] B. Lax, K. Button, *Microwave Ferrite and Ferrimagnetics*, McGraw-Hill, New York, 1962.
- [7] N. K. Saxena, N. Kumar, and P. K. S. Pourush, "Microstrip Rectangular Patch Antenna Printed on LiTi Ferrite with Perpendicular DC Magnetic Biasing", *The Journal of American Science*, vol. 6, no. 3, pp. 47-51, 2010.
- [8] S. N. Das, S. K. Chowdhury, "Rectangular Microstrip Antenna on a Ferrite Substrate", *IEEE Trans. Antennas and Propagation*, vol. 30, pp. 499-502, 1982.
- [9] S. N. Das, S.K. Chowdhury, and J. S. Chatterjee, "Circular Microstrip Antenna on a Ferromagnetic Substrate", *IEEE Transactions. Antennas & Propagation*, vol. 31, pp. 188-190, 1983.
- [10] D. M. Pozar, V. Sanchez, "Magnetic Tuning of a Microstrip Antenna on a Ferrite Substrate", *Electronic Letters*, vol. 24, pp. 729-731, 1988.
- [11] H. Y. Yang, J. A. Castaneda, "Infinite Phased Arrays of Microstrip Antennas on Generalized Anisotropic Substrate" *Electromagnetics*, vol. 11, pp. 107-124 1991.
- [12] I. Y. Hsia, H. Y. Yang, and N. G. Alexofoulos, "Basic Properties of Microstrip Circuit Elements on Non-reciprocal Substrate - Superstrate Structures", *Electromagnetics Waves and Applications*, vol. 5, no. (4/5), pp. 465-476, 1991.
- [13] J. C. Batchelor and R. J. Langley, "Beam Scanning using Microstrip Line on Biased Ferrite" *Electronic Letters*, vol. 33, no. 8, pp. 645-646, 1997.
- [14] G. F. Dionne, D. E. Oates, and D. H. Temme, "Ferrite-Superconductor Microwave Phase Shifters", *IEEE Transactions on Magnetics*, vol. 30, pp. 4518-4520, 1994.
- [15] G. F. Dionne, D. E. Oates, and D. H. Temme, "YBCO/Ferrite Low-Loss Microwave Phase Shifter", *IEEE Transactions on Applied Superconductivity*, vol. 5, pp. 2083-2086, 1995.
- [16] G. F. Dionne, D. E. Oates, D. H. Temme, and J. A. Weiss, "Ferrite Superconductor Devices for Advanced Microwave Applications", *IEEE Transaction on. Microwave Theory and Techniques*, vol. 44, no. 5, pp. 1361-1368, 1996.
- [17] G. F. Dionne, "Properties of Ferrites at Low Temperatures", *Journal of Applied Physics*, vol. 80, pp. 5064-5069, 1997.
- [18] R. C. Hansen, M. Burke, "Antenna with Magneto-Dielectrics", *Microwave Optical Technology Letters*, vol. 26, no. 2, pp. 75-78, 2000.
- [19] M. K. Karkkainen, S. Tretyakov, and P. Ikonen, "Numerical Study of Pifa with Dispersive Material Fillings" *Microwave and Optical Technology Letters*, vol. 45, no. 1, pp. 5-8, 2006.
- [20] P. Ikonen, S. Maslovski, and S. Tretyakov, "PIFA Loaded with Artificial Magnetic Material: Practical Example for Two Utilization Strategies", *Microwave and Optical Technology Letters*, vol. 46, no. 3, pp. 205-210, 2005.
- [21] M. Karkkainen and P. Ikonen, "Patch Antenna with Stacked Split-Ring Resonators as Artificial Magneto-Dielectric Substrate", *Microwave and Optical Technology Letters*, vol. 46, no. 6, pp. 554-556, 2005.
- [22] N. K. Saxena, P. K. S. Pourush, and Nitendar Kumar, "Switching Characterization of Ferrite Substrate due to Generation of Magnetostatic and Spin Waves", *International Journal of Microwave and Optical Technology*, vol. 5, no. 4, pp. 186-19, 2010.
- [23] K. K. Tsang, R. J. Langley, "Design of Circular Patch Antennas on Ferrite Substrate", *IEE Proc. Microwave Antenna Propagation*, vol.145, pp. 49-55, 1998.
- [24] P. Y. Ufimtsev, R. T. Ling, and J. D. Scholler, "Transformation of Surface Waves in Homogenous Absorbing Layers", *IEEE Transaction on Antennas and Propagation*, vol. 48, pp. 214-222, 2000.
- [25] B. Horsfield, J. A. R. Ball, "Surface Wave Propagation on Grounded Dielectric Slab Covered by a High-Permittivity Material", *IEEE Microwave and Guided Wave Letters*, vol. 10, pp. 171-173, 2000.
- [26] B. Lax, K. Button, *Microwave Ferrite and Ferrimagnetics*, McGraw-Hill, New York, 1962.
- [27] P. Kabos, V. S. Stalmachov, *Magnetostatic Waves and their Applications*, Chapman and Hall, 1994.
- [28] M. S. Sodha, N. C. Srivastav, *Microwave Propagation in Ferrimagnetics*, Plenum Press, 1981.
- [29] I. Hsia, H. Y. Yang, and N. G. Alexopoulos, "Microstrip Antennas on Ferrite Substrates", *Antennas and Propagation Society International Symposium*, pp. 370-373, 1990.
- [30] N. K. Saxena, N. Kumar, P. K. S. Pourush, S. K. Khah, "Study of Magnetic Properties of Substituted Litizn-Ferrite for Microwave Antenna Applications", *Optoelectronics and Advanced Materials - Rapid Communications*, vol. 4, no. 3, pp. 328-331, 2010.
- [31] I. J. Bahl, P. Bhartia, *Microstrip Antennas*, Artech House, Norwood, M. A, 1980.
- [32] C.A. Balanis', *Antenna Theory Analysis and Design*, Harper & Row Publisher, 1982.